

Curve Driven Patterns

Inventor’s Rectangular Feature Pattern contains advanced options for complicated patterns of geometry including curve driven patterns based on curve length, distance, and spacing along a curve. The **Curve Length** option uses the length of the path geometry (e.g., line, spline) as the total distance between the first and last occurrence, and coupled with more complex sketches this type of Pattern is quite powerful.

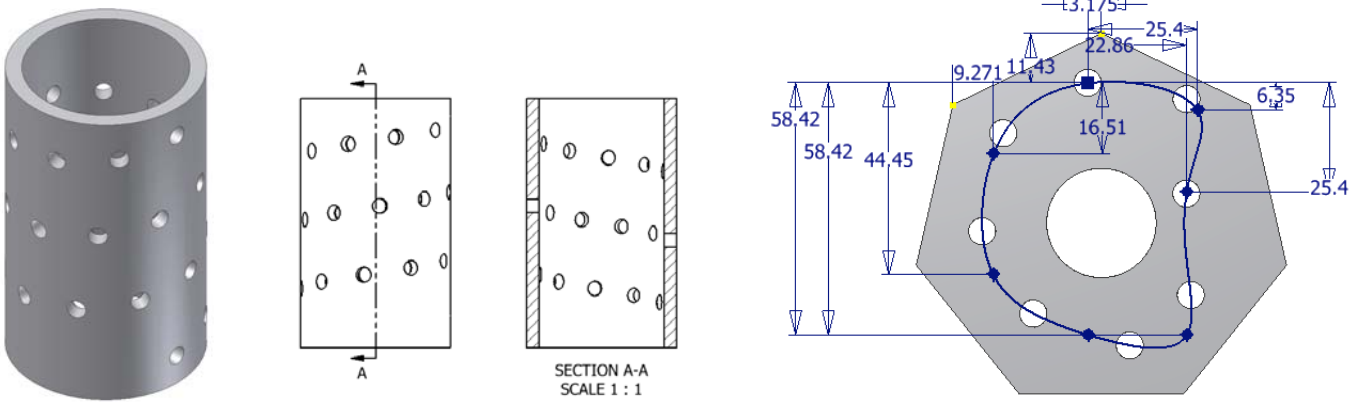

This exercise will also showcase some of the more advanced modeling approaches available in the Inventor Part environment including advanced patterns, coiled surfaces, and 3D Intersection curves.



Task 1: Create a New Part and Basic Shape

In this task a basic shape is created but this shape allows for complex design later in the exercise. A curve driven pattern can exist on simpler geometry like flat faces or cylinders as well. The steps outlined in Tasks 1 and 2 create a solid foundation for the geometry that will be built later and maintain a healthy parametric relationship for updating and revision throughout the design phase. Parameter relationships will be utilized for stability.

Note: In place Parameter name definitions performed in the following tasks are only available in Inventor 2010. For previous versions rename the parameters directly in the Parameters dialog box.

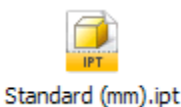

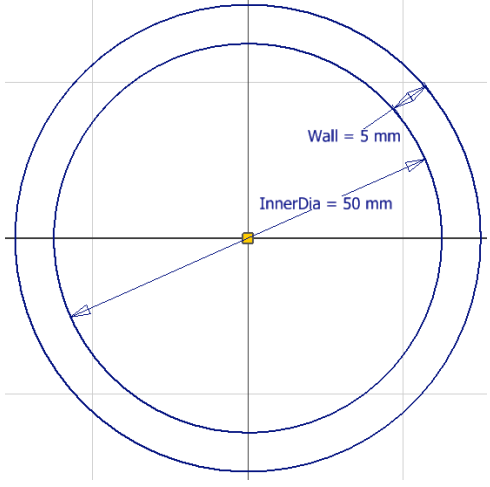
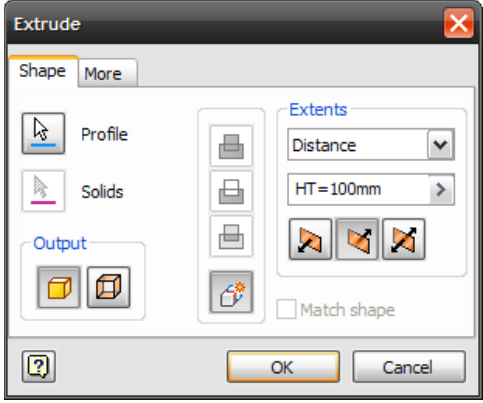
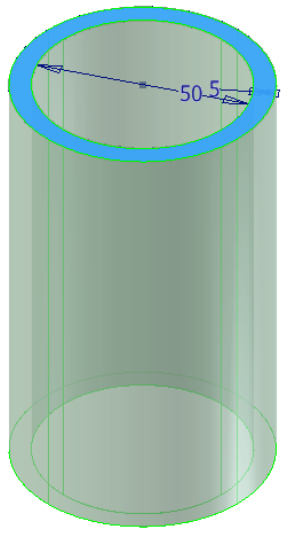

Step	Action and Instruction	Result and Screenshots
1.	<p>Create a New Part</p> <p>Make sure your default sketch plane is set to XY in your Application Options.</p> <p>Create a Part using the Standard (mm).ipt template on the Metric tab.</p>	
2.	<p>Sketch the Basic Profile</p>	

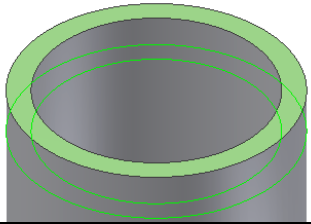

<p>Sketch the profile as shown on the right taking care to anchor it to the origin of the model with constraints. Create Parameters in Place during the creation.</p>  <p>Finish the Sketch.</p>	
<p>3. Extrude the Shape</p> <p>Start the Extrude command and use HT=100mm for the Extents and creation against the normal of the plane.</p> 	

Task 2: Create a 3D Path for Pattern

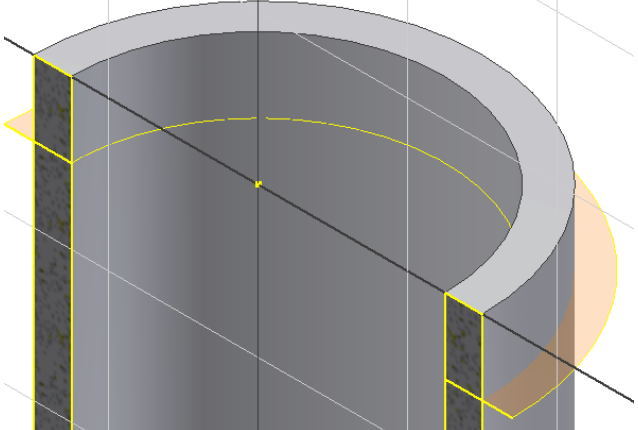
The steps in this task are some of the most complicated for creating geometry, but are very powerful. On simpler shapes a simple line, arc, circle, or spline can suffice for a curve driven pattern.

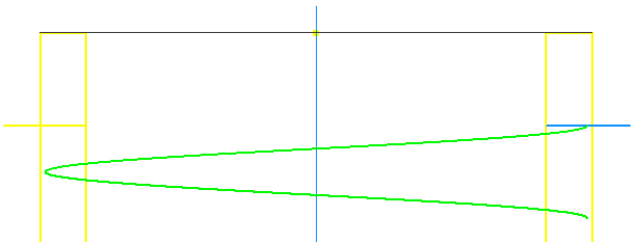
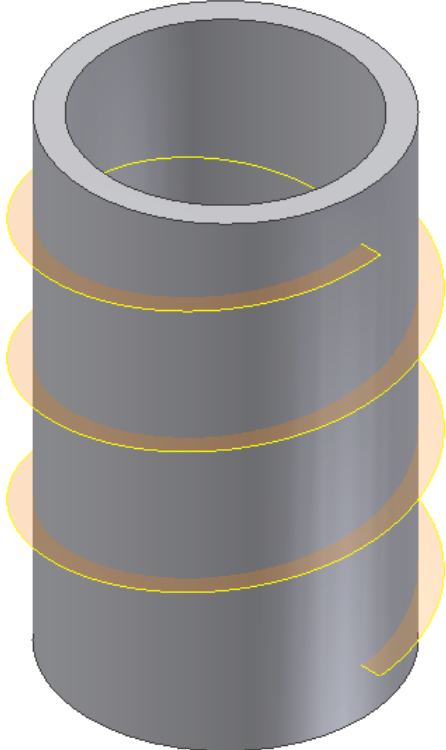

Step	Action and Instruction	Result and Screenshots
1.	<p>Create a Coil profile</p> <p>Use Thicken/Offset to offset the top face into the cylinder; Use Offset=10mm.</p> 	

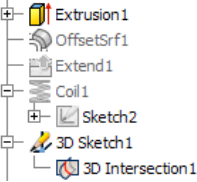
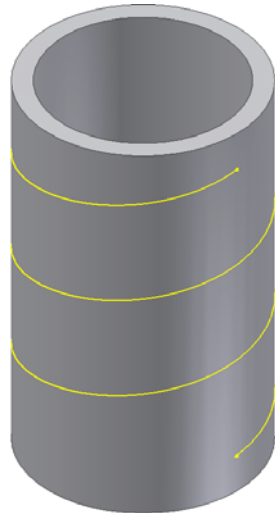
<p>2.</p>	<p>Create a Coil Sketch</p> <p>Use  Extend on the Offset Surface (located on the Expanded portion of the Surface Panel); Accept the defaults.</p> <p>Create a new 2D sketch on the XZ Plane.</p> <p>Use F7 to slice the graphics.</p> <p>Use  Project Cut Edges (located in Project Geometry fly out).</p> <p>Finish the Sketch and turn off the Visibility of the OffsetSrf1 (Extend1 will turn off as well).</p>	
<p>2.</p>	<p>Create a Coil</p> <p>Start the  Coil command.</p> <p>Select Surface as the Output Type. </p> <p>Select the small line profile in the 2D sketch.</p> <p>Select the Z axis for the coil axis reference.</p> <p>Ensure the Shape Axis builds toward the bottom of the cylinder.</p> <p>Click on the Coil Size tab.</p>	
<p>3.</p>	<p>Define Coil Size</p> <p>Choose Revolution and Height from the pull down list.</p> <p>For Height use: $CoilHT = HT - 2*Hoffset.$</p> <p>For Revolutions: 3.00</p> <div data-bbox="305 1203 735 1524" style="border: 1px solid gray; padding: 5px;"> <p>Type <input type="text" value="Revolution and Height"/></p> <p>Pitch <input type="text" value="10 mm"/> Height <input type="text" value="HT-2*Hoffset"/></p> <p>Revolution <input type="text" value="3.00"/> Taper <input type="text" value="0.00"/></p> </div> <p>Click OK</p>	
<p>4.</p>	<p>Create Intersection Curve</p>	

<p>Start a new 3D sketch.  Create 3D Sketch</p> <p>Click Intersection Curve ().</p> <p>Select the outside surface of the cylinder and the coiled surface as references.</p> <p>Click OK and Finish the Sketch.</p> <p>Turn off the Visibility of Coil1.</p> 	
---	---

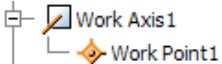
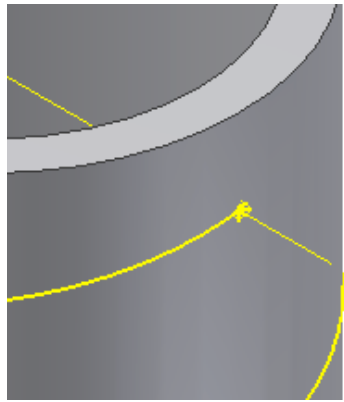
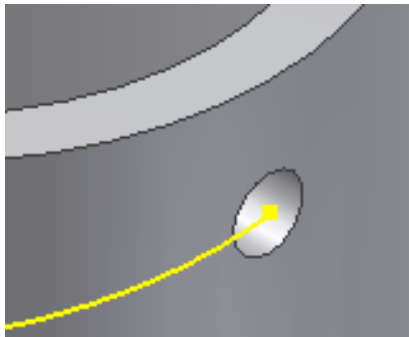

Task 3: Create a Hole on the Shape

In this task a Hole is created using an On Point approach to properly place itself on the cylindrical shape. This also adds more flexibility with its reference features for the Hole as described in the next task.

Step	Action and Instruction	Result and Screenshots
1.	<p>Create Hole References</p> <p>Create a  Point at the beginning of the Intersection Curve.</p> <p>Create a  Axis by selecting the new Work Point in the browser (be careful not to select the start point of the curve) and the outer face of the cylinder. This will create a Work Axis perpendicular to the face through the Work Point.</p> 	
2.	<p>Create a Hole</p> <p>Start the Hole Command.</p> <p>Select On Point from the drop down placement list. Select the Work Point and the new Axis for the Placement References (you may have to flip the termination).</p> <p>Assign Wall to Hole Depth.</p> <p>Create HoleDia=6mm for Hole Width.</p> <p>Turn off the Visibility of the Work Point, Work Axis, and Coiled Surface created for the Hole.</p>	

Task 4: Pattern the Features

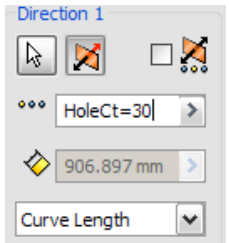
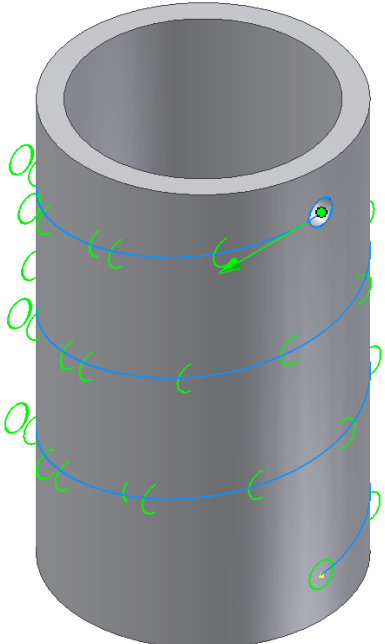
In the previous task, a Hole is created for eventual use in the curve driven pattern. This is ideal if the holes are identical throughout the pattern; however, if the holes are not to be identical the pattern should consist of the Work Axis and Work Point alone for individual precise feature creation.

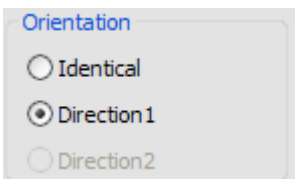
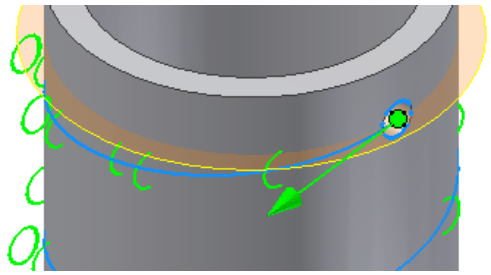
Step	Action and Instruction	Result and Screenshots
1.	<p>Create a Rectangular Pattern</p> <p>Start  Rectangular</p> <p>Select the Hole feature for Pattern.</p> <p>Select Direction 1 Arrow and choose the intersection curve. Make sure the direction creates in the vector of the curve.</p> <p>Select Curve Length from the drop down for the feature placement of Direction 1. This will input a grayed out value that is the length of the actual intersection curve.</p> <p>Use <i>HoleCt=30</i> in the Count field.</p> 	
2.	<p>Adjust Advanced Settings</p> <p>Expand the more chevrons. </p> <p>Change the Orientation of the feature to Direction 1 rather than the default Identical.</p> <p>This will maintain the feature's creation to be tangent to the 2D vector of the path based on the first feature.</p>  <p>Click OK.</p> <p>From this exercise you can start to imagine the depth of complex patterns that can arise during the modeling process and can now look beyond standard Rectangular Pattern.</p>	<p>Identical Orientation</p>  <p>Direction 1 Orientation</p> 